



HARKEN[®]
PowerSeat
PWRB-B
PWRB-B.Compact
Instruction Manual



Please read these instructions carefully before operating equipment.



English Translation

Rev. 00 FT

UPS_16/09-2014



Introduction	page	7
About this Manual	page	7
Glossary and Symbols	page	8
General Information	page	9
Identification Data and Plates on the Device	page	9
Model of Declaration of Compliance	page	10
Standard References	page	11
FCC Verification	page	12
IC Certification	page	12
Technical Support Information	page	12
Safety Precaution	page	13
General Advice	page	13
Intended Use	page	13
Improper Use	page	14
Safety Devices	page	14
Personal Protective Equipment (PPE)	page	14
Residual Risks	page	14
Informations on the Power System	page	16
Battery Description	page	16
<i>General</i>	page	16
<i>Technical Data</i>	page	17
<i>Light Interface</i>	page	17
Safety Informations	page	17
Using the Battery	page	18
Charge the Battery	page	19
Store and Shipping	page	20
PowerSeat PWRS-B	page	22
Device Description	page	22
<i>General</i>	page	22
<i>Dimensions</i>	page	23
<i>Safe Working Load</i>	page	24
<i>Rope Requirements</i>	page	24
<i>Vibration</i>	page	24
<i>Noise Emission</i>	page	24
<i>Technical Data</i>	page	24
<i>Motor</i>	page	25
Using the Device	page	25
<i>Checking the Device Before Use</i>	page	25

<i>Adjusting the Accelerator Control Position</i>	page	28
<i>Adjusting the Control Lever Position</i>	page	29
<i>Primary Rope Installation Procedure</i>	page	30
<i>Wiring the Battery</i>	page	33
<i>Preparing to Ascent</i>	page	34
<i>Ascent Procedure 1</i>	page	35
<i>Ascent Procedure 2</i>	page	37
<i>Using PowerSeat with a fixed Anchorage</i>	page	38
<i>Descent Procedure 1</i>	page	40
<i>Descent Procedure 2</i>	page	41
<i>Fixed Anchorage Descent Procedure</i>	page	41
<i>Transport and Storage</i>	page	41
PowerSeat PWRS-B.Compact	page	42
Description of Compact version	page	42
<i>General</i>	page	42
<i>Dimension</i>	page	43
Using the Compact version Device	page	44
<i>Checking the Compact version Device Before Use</i>	page	44
<i>Primary Rope Installation Procedure on Compact version</i>	page	44
<i>Preparing to Ascent with the Compact version</i>	page	46
<i>Ascent Procedure with the Compact version</i>	page	46
<i>Using Compact version PowerSeat with a Fixed Anchorage</i>	page	47
<i>Descent Procedure with the Compact version</i>	page	49
<i>Fixed Anchorage Descent Procedure with the Compact version</i>	page	49
<i>Converting the PowerSeat PWRS-G into the Compact version</i>	page	49
Maintenance	page	51
Cleaning	page	51
Maintenance	page	51
Dismalting and Disposal	page	51
Diagnosis and Fault Finding	page	51
PowerSeat and Motor	page	51
Battery	page	52
Maintenance Schedule	page	53
Worldwide Limited Warranty	page	56

About this Manual

This User Manual is an integral part of the device and aims to provide all the information needed for its safe and correct use and for proper maintenance.

If there are instructions you do not understand, contact Harken.

Keep the manual in a safe place for future consultation. This manual may be modified without notice. Updated versions are available on www.power-seat.com.

This manual is for qualified operators (refer to the Safety Information chapter for more information). Improper use of the device or incorrect maintenance could cause severe damage or death.

Harken accepts no responsibility for damage, personal injury or death caused by failure to observe the safety information and instructions in this Manual. The device must be used exclusively by qualified operators in possession of a certificate for temporary work at height with the use of access and positioning systems using ropes according to the current regulations of the Nation in which the device is used. This manual thus supplies information exclusively regarding the correct use of the device and does not substitute the training and certification needed for temporary work at height with the use of access and positioning systems using ropes.

GLOSSARY AND SYMBOLS

Intended Use – use of the device according to the information supplied in the instructions for use.

Improper Use – use of the device in a way different from that indicated in the instructions for use.

Qualified Operator – persons who have attended specialisation, training etc courses and are certified for temporary work at height with the use of access and positioning systems using ropes according to the current regulations of the Nation in which the device is used.

User – qualified operator of the device

Anchorage – point of attachment of the rope or device to a fixed point.

Primary (working) rope – main rope used for ascending or descending using the device (approved according to EN 1891).

Secondary (backup) rope – safety rope to protect the operator from falling if the primary rope breaks (approved according to EN 1891).

Fall Arrest – individual protection device that brakes the fall of the user (EN353/2 approved).

Text preceded by the following symbols contains very important information or instructions, especially in regards to safety.

Failure to observe these may lead to:

danger for operators

invalidity of the contract warranty

refusal of the manufacturer to accept responsibility



WARNING!

this denotes the existence of the potential danger, which could cause injury or damage if the information or instructions are not followed



NotE!

this denotes important information concerning the device

IDENTIFICATION DATA AND PLATES ON THE DEVICE

Each device is identified by a CE plate on which the reference data of the device are inscribed indelibly. Always quote these references when contacting the manufacturer or service centres.

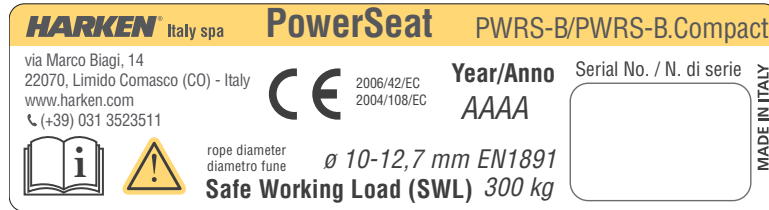

1	2		
3	4	5	6
7	8		

1. name of manufacturer
2. name of product and model
3. manufacturer's identification data
4. CE mark according to 2006/42/CE
5. year of manufacture
6. serial number in the format:

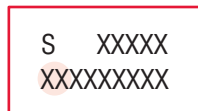

last two numbers of the year of manufacture of the device (e.g. 13 = the year 2013)

7. pictogram instructing you to read the manual before using the device
8. safety instruction on the diameter of the rope to use: minimum 10 mm, maximum 12.7 mm: this rope must be EN 1891 certified, plus indication of the Safe Working Load (SWL) of the device

The CE plate is on the chassis of the device:



MODEL FOR DECLARATION OF COMPLIANCE

DECLARATION OF EC COMPLIANCE

1. (AII. IIA Dir. 2006/42/CE)

The undersigned

Harken Italy S.p.A.

Via Marco Biagi, 14, 22070 Limido Comasco (CO) Italy

Telephone: +39 031/3523511, Fax: +39 031/3520031

Email: italy@harken.it, Web: www.harken.it

hereby declares that the machine:

LIFTING SYSTEM OF PEOPLE AND THINGS BY USING TECHNICAL ROPES

Model

POWERSEAT PWRS-E

POWERSEAT PWRS-E.Compact

Serial Nr.



Year of Manufacture

YYYY

complies with the essential requirements defined by the following directives:

- ⇒ Directive 2006/42/CE of the European Parliament and Council of 17th May 2006 on machinery, and amending Directive 95/16/CE;
- ⇒ Directive 2004/108/CE of the European Parliament and Council of 15 dicembre 2004 on the approximation of the laws of the Member States relating to electromagnetic compatibility;
- ⇒ Regulations reference: UNI EN ISO 12100:2010, EN 60204-1, EN ISO 13850, EN ISO 13849-1, EN ISO 13857, CEI EN 61000-6-2, CEI EN 61000-6-4

and authorises

Name and Surname:

Adress: HARKEN ITALY S.p.A. Via Marco Biagi, 14

CAP: 22070

Province: Como

Città: Limido Comasco

Nazione: Italia

to carry out the technical file for it

Certification services: **Bureau Veritas Italia S.p.A.**

HARKEN ITALY S.p.A.

Certificatio Nr: **XXXX-XXXX-XX-XXXX-XX-XXXX**

Date of issue: **MM/YYYY**

Limido Comasco, li **DD/MM/YYYY**

.....
Legal representative

STANDARD REFERENCES

The device has been manufactured in conformity with the TECHNICAL REGULATIONS listed below:

Reference technical standards	
UNI EN ISO 12100:2010	Safety of machinery -- General principles for design -- Risk assessment and risk reduction
UNI EN ISO 13850:2008	Safety of machinery - Emergency stop system, functional aspects
UNI EN ISO 13857:2008	Safety of machinery -- Safety distances to prevent hazard zones being reached by upper and lower limbs
UNI EN 349:2008	Safety of machinery - Minimum gaps to avoid crushing of parts of the human body
UNI EN 1037:2008	Safety of machinery - Prevention of unexpected start-up
EN ISO 13849-1:2008	Safety of machinery – Safety-related parts of control systems – Part 1: General principles for design
EN ISO 13849-2:2008	Safety of machinery – Safety-related parts of control systems – Part 2: Validation
UNI EN ISO 13732-1:2007	Ergonomics of the thermal environment - Methods for the assessment of human responses to contact with surfaces - Part 1: Hot surfaces
UNI EN 614-1:2006	Safety of machinery - Ergonomic design principles - Part 1: Terminology and general principles
UNI EN 614-2:2009	Specification and qualification of welding procedures for metallic materials - Welding procedure test - Part 2: Arc welding of aluminium and its alloys
UNI EN 953:2009	Safety of machinery - Guards - General requirements for the design and construction of fixed and movable guards
UNI EN 1005-1:2009	Safety of machinery - Human physical performance - Part 1: Terms and definitions
UNI EN 1005-3:2009	Safety of machinery - Human physical performance - Part 3: Recommended force limits for machinery operation
UNI EN 1005-4:2009	Safety of machinery - Human physical performance - Part 4: Evaluation of working postures and movements in relation to machinery
UNI EN ISO 3746:2011	Acoustics - Determination of sound power levels and sound energy levels of noise sources using sound pressure - Survey method using an enveloping measurement surface over a reflecting plane
UNI EN ISO 11204:2010	Acoustics -- Noise emitted by machinery and equipment -- Determination of emission sound pressure levels at a work station and at other specified positions applying accurate environmental corrections
UNI EN ISO 4871:2009	Acoustics - Declaration and verification of noise emission values of machinery and equipment
UNI EN ISO 7000:2012	Graphical symbols for use on equipment -- Registered symbols
CEI EN 61000-6-2	Electromagnetic compatibility (EMC) - Part 6-2: Generic standards - Immunity for industrial environments
CEI EN 61000-6-4	Electromagnetic compatibility (EMC) - Part 6-4: Generic standards - Immunity for industrial environments
CEI EN 61558-2-2	Safety of power transformers, power supply units and similar - Part 2-2: Particular requirements for control transformers
CEI EN 60204-1:2006	Safety of machinery - Electrical equipment of machines. Part 1: General rules
CEI EN 60529:1997+A1(2000)	Degree of protection provided by enclosures (IP code)
UN 38.3	Transportation testing required for Lithium battery
IEC 62281	Safety of primary and secondary Lithium cells and batteries during transport
IEC 62079	Preparation of instruction - structuring, content and presentation

General Information

FCC VERIFICATION

This device complies with Part 15 of the FCC Rules. Operation is subject to the following two conditions:

- 1) this device may not cause harmful interference
- 2) this device must accept any interference received, including interference that may cause undesired operation



Note!

This equipment has been tested and found to comply with the limits for a Class A digital device, pursuant to Part 15 of the FCC rules. These limits are designed to provide reasonable protection against harmful interference in a residential installation. This equipment generates, uses and can radiate radio frequency energy and, if not installed and used in accordance with the instructions, may cause harmful interference to radio communications. However, there is no guarantee that the interference will not occur in a particular installation. If this equipment does cause harmful interference to radio or television reception, which can be determined by turning the equipment off and on, the user is encouraged to try to correct the interference by one or more of the following measures:

- Reorient or relocate the receiving antenna.
- Increase the separation between the equipment and receiver.
- Connect the equipment into an outlet on a circuit different from that of the receiver.
- Consult the dealer or an experienced radio/TV technician for help.

IC CERTIFICATION

This Class A digital apparatus meets all requirements of the Canadian Interference-Causing Equipment Regulations.

TECHNICAL SUPPORT INFORMATION

The PowerSeat is covered by a warranty, as laid down in the general conditions of sale. If during the warranty period the device proves defective or suffers breakages, as indicated in the warranty, the manufacturer, after checking the device, will repair or replace the defective components. You are reminded that modifications carried out by the user, without explicit written authorisation from the manufacturer, will invalidate the warranty and relieve the manufacturer of any responsibility for damage caused by the defective product. The same considerations apply when spare parts that are not original or different from those explicitly indicated by the manufacturer as “safety devices” are used. For all these reasons we advise customers to contact Harken Technical Support.

GENERAL ADVICE**WARNING!**

read the instructions in this manual attentively and carefully follow the indications it contains before using the PowerSeat

Use of the PowerSeat is restricted to qualified operators who are certified for temporary work at height with the use of access and positioning systems using ropes according to the current regulations of the Nation in which the device is used.

Harken is not responsible for damage caused by the PowerSeat to people, animals or property in the case of:

- use of the PowerSeat by operators without proper certification
- improper use of the PowerSeat
- lack of proper maintenance, as indicated in the Maintenance chapter of this Manual
- unauthorised modifications or changes
- use of spare parts that are not original or specific for the model
- total or partial failure to observe the instructions
- usage contrary to specific national regulations

INTENDED USE

The PowerSeat is designed to help qualified operators ascend a rope using the engine and descend using a passive manual device. The PowerSeat is not safety equipment and is not a Personal Protective Equipment. It must always be used in combination with a secondary rope to which is connected the fall arrest device fixed to the operator's harness by a cord with an energy absorber, and must satisfy the requirements of EN 363 on individual systems for the protection against falling from heights.

In order to use the PowerSeat a risk analysis, and rescue plan must have been drawn up, as required by current regulations of the nation where the device is used on temporary work at height and the use of access and positioning systems using ropes.

The following guidelines must also be considered:

- ISO 22846: Personal equipment for protection against falls (Part 1/Part 2)
- IRATA: International Code of Practice.
- C(HSW)R: The Construction (Health, Safety and Welfare) Regulations.
- LOLER: The Lifting Operations and Lifting Equipment Regulations.
- MHSWR: The Management of Health and Safety at Work Regulations.
- PUWER: The Provision and Use of Work Equipment Regulations

This list is not complete and it is the responsibility of the qualified operator to be aware of current regulations in his country on temporary work at height and the use of access and positioning systems using ropes or other regulations relating to his specific sector of work.

Safety Precaution

IMPROPER USE

The machine must not be used:

- for purposes different from those outlined in “Intended use” chapter, or for purposes not mentioned in this manual or different from those mentioned
- if unauthorised modifications or interventions have been carried out
- in an explosive atmosphere
- after it has fallen from a height of more than 1mtr onto a hard surface. In this case the device must be returned to the manufacturer or to a Harken authorised repair centre.

SAFETY DEVICES

The following safety devices are installed:

- Fall arrest attachment consists of strap and carabiner locked to the main support plate certified according to EN 1275; EN 362 Standards.
- Plastic cover on the central support for protecting the device from contact shocks and rope jamming.
- Shaped plastic guard between the descending knob and the rope entry on the winch to prevent the rope jamming and tangling.
- Plastic cover containing the electric motor to protect from hot parts.

PERSONAL PROTECTIVE EQUIPMENT (PPE)

The device bears an adhesive label reminding you of the obligation:

- to use gloves



RESIDUAL RISKS

You must pay attention to the following residual risks present when using PowerSeat:



WARNING! Rotating Parts Trapping Risk

Always wear clothing and protective gloves that are form fitting. Avoid loose gloves or clothing and always follow the instructions in the manual.



WARNING! RiSk of Falling

Always use personal protective equipment and always follow the instructions of the manual.



WARNING! Hot Parts

See Notes reported in the electrical equipment description.



WANRING!

The plug of the machine / power supply must be suitable for the socket. Never modify the plug. Conformed plugs and suitable sockets reduce risk of electric shock.



WARNING!

Do not use the device with faulty switches.
Devices or control systems with faulty switch are dangerous and require maintenance.



WARNING!

Do not remove the motor carter.

Information on the power system

BATTERY DESCRIPTION - GENERAL

The PowerSeat battery is specially designed to supply exclusively the PowerSeat engine. Such battery is a Lithium-ion battery (Li-Ion) with an high energy density, which allows to optimize the performance of the PowerSeat. The battery has a BMS (Battery Management System) specially designed to enhance security and optimize life cycle of the battery.

Like all other batteries with lithium-ion technology, its use presents risks if not properly used, stored and reloaded.



WARNING!

Read carefully this manual because the improper use, storage and charging Harken battery, it could cause the battery explosion resulting in a fire which could cause serious injury to persons or property.

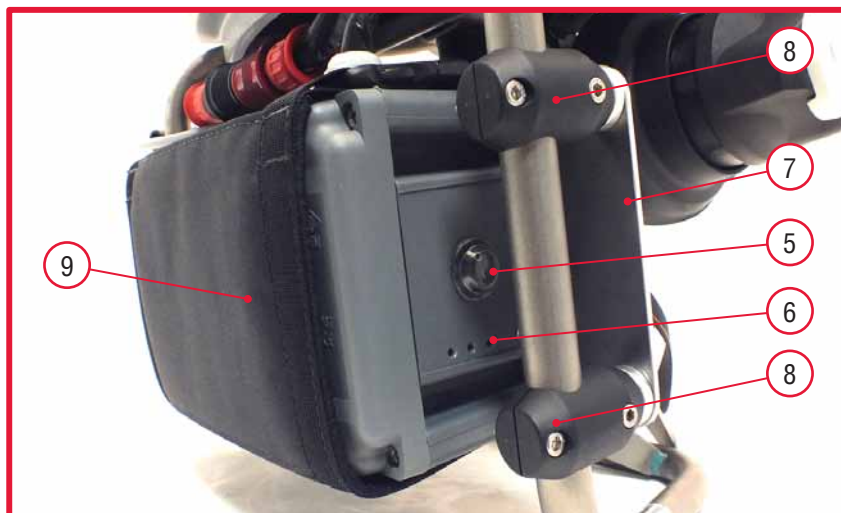

Pos.	Description
1	Battery
2	Motor power cable
3	Power outlet of the battery
4	Cover attacks protective
5	Switch 0/1

Pos.	Description
6	LED lights
7	Support battery
8	Battery support attacks
9	Protective cover

BATTERY DESCRIPTION - TECHNICAL DATA

Type	Li-Ion
Cells	Panasonic
Nominal Voltage	50,4 Vdc
Rated charging current	2 A
Current short-circuit	100 A
Interruption time for the short-circuit	100 ms
Temperature range in download	-10 °C / +50 °C
Temperature range in upload	0 °C / +40 °C
Dimensions (WxLxH)	240x144x93 mm
Weight	3,6 kg
Thermal Protection (charging/discharging)	electric control
Degree of Protection	IP54
Operating ambient temperature	-10° C / +50° C
Work environment	internal and external use

BATTERY DESCRIPTION - INTERFACE LIGHT

The switch “0/I” turns on and off the battery. The interface light located laterally on the battery, provides information on the battery charge through 3 LEDs.

Turning on the battery, the LEDs are turned on sequentially until reaching the one that that represents the state of the battery:

LED	Description
Green	State of charge between 100% and 50%
Yellow	State of charge between 50% and 20%
Red blink	State of charge between 20% and 5%
Red fixed	State of charge less than 5%

If during the battery discharge, the remaining charge drops below a predetermined threshold there will be a commutation of the state of the LEDs.

SAFETY INFORMATION



WARNING!

Do not use batteries of PowerSeat to power other electrical products.



WARNING!

Do not disassemble or modify the battery.



WARNING!

An old battery, or a completely discharged battery, or a battery that has less than 80% of the initial capacity, or a battery that present the poor performance should be taken out of service and replaced with a new battery.

Information on the power system



WARNING!

Put immediately the battery out of service if there are any visible damage to the outer casing or to the cables or to the connectors or if it has been dropped, even if damage is not visible.



WARNING!

Put immediately out of service and place in an isolated area, outside and away from combustible or flammable substances, the battery that emanates a strange smell, is too hot, or presents abnormalities.



WARNING!

Do not short-circuit the battery, as this could cause serious damage to people and property.



WARNING!

Do not immerse the battery in water.

BATTERY USAGE



NOTE!

When you purchase the battery, perform a complete charge cycle to preserve its useful life.

Battery performance depends on the temperature of the batteries.

The use of the battery at low temperatures, affect the performance of the PowerSeat and the ascent rate will be limited. The return of the battery to temperatures in the range of use allows you to get the expected performance.



NOTE!

Use the battery at a temperature between -10°C/+ 50°C.



WARNING!

Exposure of batteries to a temperature greater than 60°C can cause irreversible damage to the battery and cause a fire.



WARNING!

Use the battery according to the environmental specifications! Improper use can damage electronic circuits.



NOTE!

The battery automatically shuts off after 4 hours of non-use. To turn the battery off and turn on the switch 0/1.



NOTE!

In case of short circuit of the battery, this should be sent to Harken for maintenance, subject to authorization by Harken.

In the case of short-circuit of the battery, the power interruption occurs through the breaking of the series of the two components mosfet and Hall effect current sensor. The value of the short-circuit operation is 100A, the interruption time is 100 ms. Following the short-circuit, LEDs will be turned off.

BATTERY CHARGING

To recharge the battery, use a charger with the following specifications:

Chargers for batteries	12 celle Li-Ion
Mains voltage	198/264 Vac
Output Voltage	50,4 Vdc
Rated charging current	2 A
Mains frequency	47-63 Hz

To recharge the battery, follow the procedure:



WARNING!

Before connecting the charger to the power supply, make sure that the power supply voltage is within the range specified in the specifications of the charger.

1. turn off the battery
2. disconnect the battery from the PowerSeat
3. connect the charger to the electricity
4. connect the battery off to the charger
5. turn on the battery through the switch "0/1"

During the charging, the LED that represent the state of charge, is flashing. Upon reaching the full charge, the green LED is fixed. Cyclically, the green LED may be turned off for a while and this is due to periodic inspection carried out by the BMS, the battery charge and temperature.

During the charging, the LED on the charger is red. Once you reach the full charge of the battery, the LED on the charger turns green. When the battery is fully charged, turn off the battery through the switch 0/1 and then disconnect the charger from the power supply before removing the battery.

To recharge a completely discharged battery is needed 4h 30'. The charging process is linear.



NOTE!

The performance shown were obtained with a battery charger having the specifications listed above.

The battery gradually loses its charge up to total exhaustion. If this happens, the battery may no longer be able to operate even when connected to the charger. To avoid this situation, you must fully charge the battery at least once every 4 months, even if they are not used in this time frame.

Information on the power system

In case the temperature exceeds of + 40°C, the charge is interrupted by the BMS and the LED state of charge (on the battery) becomes fixed. The BMS cyclically controls the temperature of the battery and if it detects a temperature between 0°C / +40°C, the charging process will start again.



NOTE!

Recharge the battery after each use and at least every four months to prevent damage to the battery and preserve its useful life.



WARNING!

Use only the charger supplied by Harken to recharge the battery.



WARNING!

Charge the battery at a temperature between 0°C / +40°C.



WARNING!

Recharge the battery in a place indoors, dry, safe and not exposed to direct sunlight, away from fuel or other flammable substances, as in the case there is a serious fault in the charging of the battery, such event could cause the explosion of the battery and consequently a fire.



WARNING!

Recharge the battery only when they have reached room temperature.



WARNING!

Disconnect the battery from the charger when it finished the charging.



WARNING!

Disconnect the charger from the network when it finished the charging.

STORE AND SHIPPING



NOTE!

Store the battery charged to 100%.



NOTE!

Recharge the battery at least once every 4 months if stored for a long period of time.



WARNING!

Do not store the battery connected to PowerSeat or connected to the charger.



WARNING!

Do not store the battery turned on (with the switch in position "1").



WARNING!

Store the battery in a place indoors, dry, safe and not exposed to direct sunlight, away from fuel or other flammable substances, at a temperature between 0°C/+40°C. The storage at a higher temperature may alter the performance of the batteries reducing their expected life. The storage at a temperature greater than 60°C can cause irreversible damage to the battery and cause a fire.



WARNING!

The lithium-ion batteries Harken are classified as dangerous goods according to UN3480 - Class 9 and must be sent as specified in such legislation.



WARNING!

Do not ship a defective battery.

PowerSeat PWRS-B

DEVICE DESCRIPTION - GENERAL

The PowerSeat is designed to help qualified operators ascend a rope and descend using a passive manual device.

The rope must be inserted in its housing in the vertical tube, through the deflector sheave, wrapped round the winch drum and locked in the rope grab.

When the engine is started, a transmission system rotates the drum and creates a traction force on the rope.

Electrical motor supplies power during the ascent, start and stop is an electrical system and the control system is provided with an anti-panic system and an emergency button.

During descent the engine is switched off and the operator uses the lever to open the rope grab and allow the rope to slide round the drum in a controlled descent.

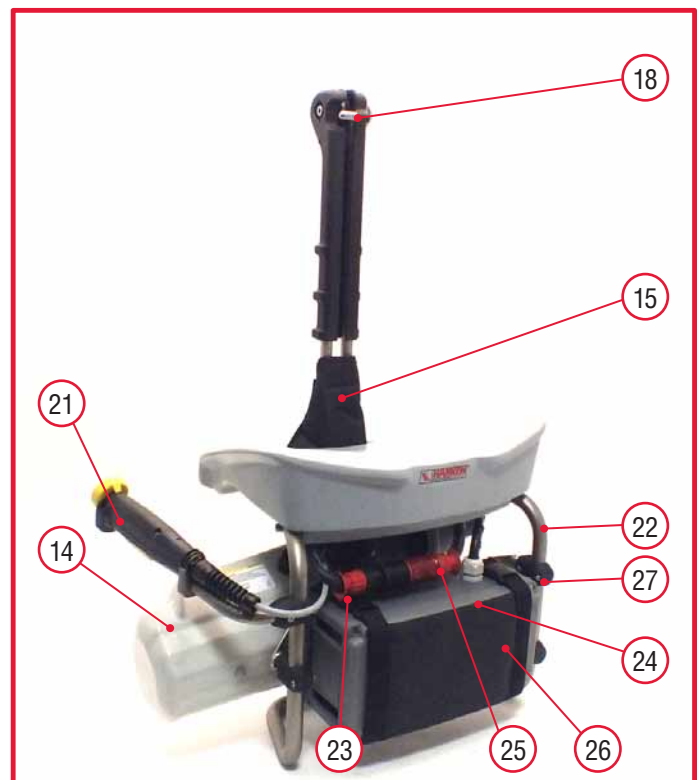
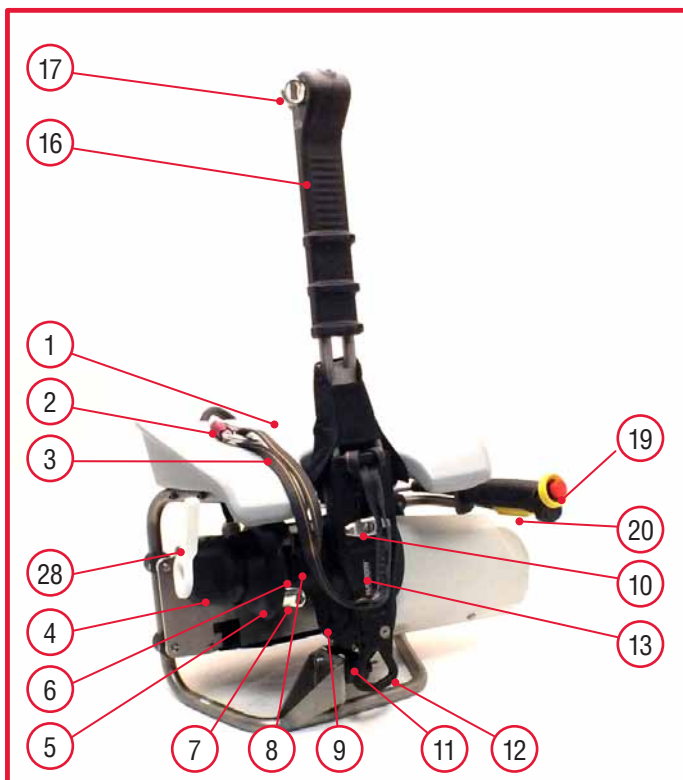

Pos.	Description
1	Seat
2	Snap-hook
3	Strop
4	Knob
5	Cover
6	Rope grab
7	Stripper arm
8	Winch Drum
9	Reduction gear casing
10	Clamp
11	Damper
12	Anchorage point
13	Front plate
14	Motor cover

Pos.	Description
15	Protection
16	Front tube
17	Eyebolt
18	Pin
19	Emergency button
20	Accelerator lever
21	Accelerator control
22	Frame
23	Power cable
24	Battery
25	Battery power cable
26	Protection Pad
27	Battery support plate
28	Control lever

DEVICE DESCRIPTION - DIMENSIONS

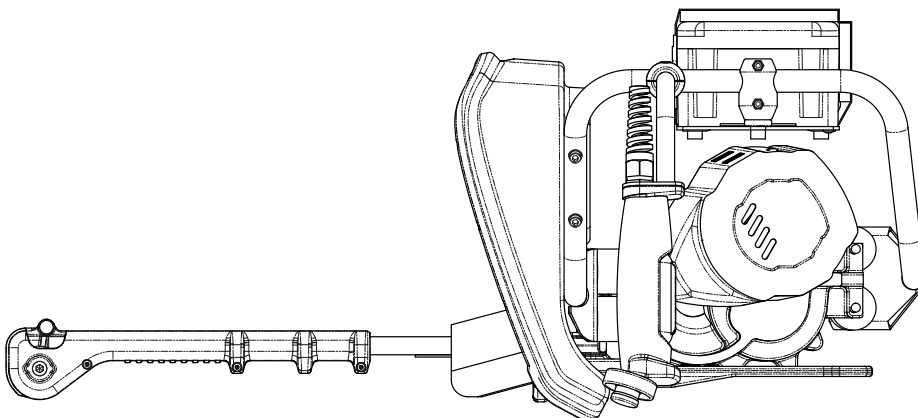
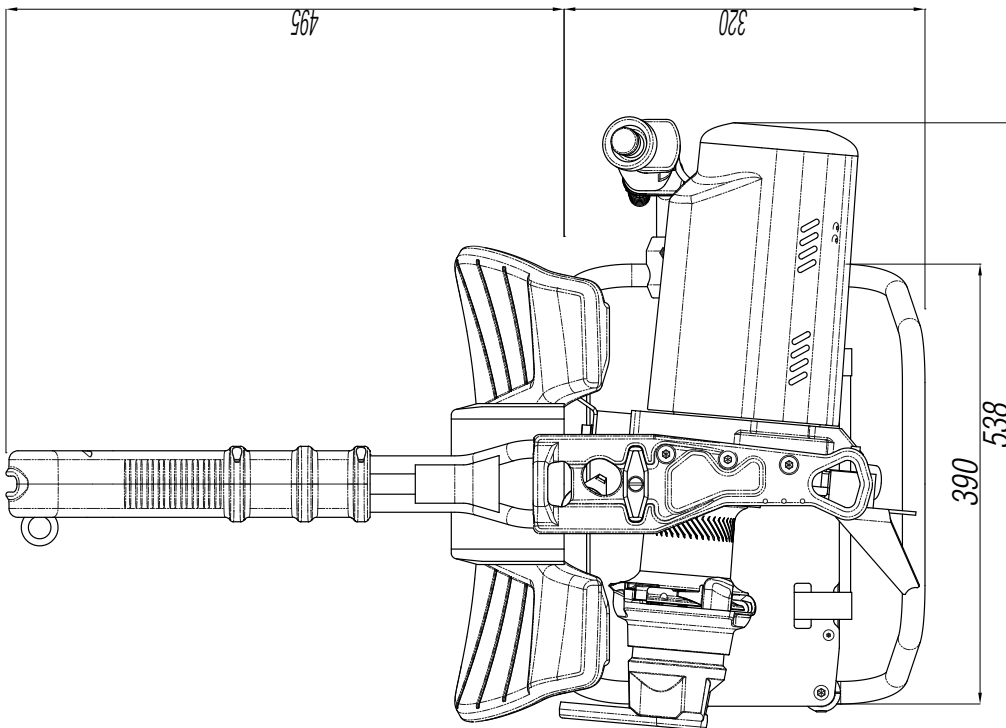
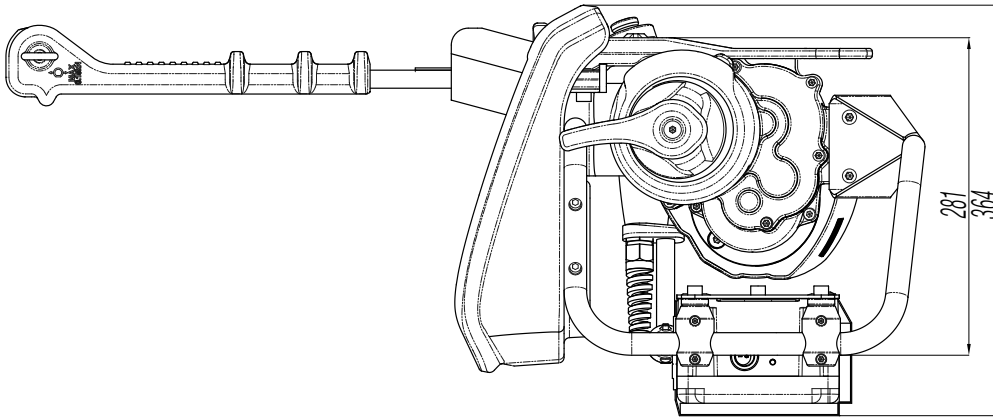

PowerSeat PWRS-B

DEVICE DESCRIPTION - SAFE WORKING LOAD

The Safe Working Load of the PowerSeat is 300 Kg (661,4 lb).



WARNING!

Do not apply a load greater than the Safe Working Load to the PowerSeat.

DEVICE DESCRIPTION - ROPE REQUIREMENTS



WARNING!

Use only EN1891 certified ropes with a diameter of between 10 - 12.7 mm (3/8" - 1/2").



WARNING!

Use only ropes in good condition.



WARNING!

For correct maintenance of ropes consult the rope Usage Manual.

DEVICE DESCRIPTION - VIBRATIONS

Vibration values measured are below the limits set by the reference standards:

Hand-arm <2,5 (A(8)m/s), Whole body <0,5 (A(8)m/s).

DEVICE DESCRIPTION - NOISE EMISSION

The values of the measured noise emissions are below the limits allowed under the applicable standards - ISO 3746:

- Average surface acoustic pressure level weighted A:

$$(L_{pfA,d} \text{ (medio)}) < 80 \text{ dB(A)}$$

- Acoustic power level weighted A (L_{WA}) < 90 dB(A)

DEVICE DESCRIPTION - TECHNICAL DATA

Below are the principal technical data of the PowerSeat obtained with a rope 11mm (7/16") in diameter at a temperature of 20°C at sea level.

Rope	Semi static 10mm-12.7mm (1/8"-1/2") EN1891 rope
Safe working load	300 kg (661,4 lb)
Maximum Load on Seat	150 kg (330,7 lb)
Ascent speed 48 V*	13,5 m/min (125 kg (275,9 lb))
<small>*with a new battery, full charged, into the temperature range of use</small>	10,8 m/min (300 kg (661,4 lb))
Reduction Ratio	48,6:1
Device Weight	19 kg (41,9 lb) + 3,6 kg (7,9 lb)
Dimensions	815 x 538 x 364 mm
Recommended working temperature range	-10 °C / +50 °C
Ingress Protection Rating	IP 54
Continuous operation distance*	550 m (125 kg (275,9 lb))
<small>*with a new battery, full charged, into the temperature range of use</small>	250 m (300 kg (661,4 lb))

DEVICE DESCRIPTION - MOTOR

Motor	Brushless electric
Nominal Voltage	48 Vdc
Net Power	0,8 kW
Thermal Protection	Activation temp. 100°C (212°F)

USING THE DEVICE - CHECKING THE DEVICE BEFORE USE

Before and after every use, visually inspect the PowerSeat for traces of wear, damage or breakage. If such traces are present, do not use the device. If the worn or defective parts are not immediately replaced, the manufacturer will assume no responsibility for resulting damage or accidents.

In particular:



Check that the strop and carabiner are intact.



Check the movement of the rope grab cover.



Check that the rope grab knob is working by rotating the control lever and releasing it (CLOSE JAW).



Check that the rope grab knob is working by rotating the control lever and releasing it (OPEN JAW).

PowerSeat PWRS-B

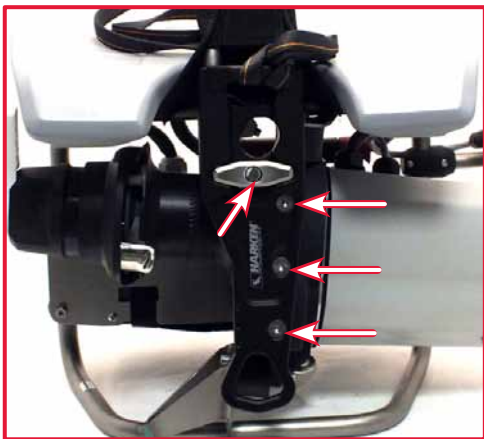

Inspect all screws and check that the marker on the screws and on the plate are aligned. In case of any misaligned contact a HARKEN service center.



Inspect the lever control screw, and all screws that secure the seat to the frame and check that they are properly tightened.



Rotate the winch drum clockwise by hand and make sure that it cannot rotate anticlockwise.



Verify that the cables and connectors on the battery/motor are in good state of maintenance and connected.



Make sure the fastening straps of the protective cover are securely closed and properly positioned.



Turn on the battery with the switch 0/1 and check the state of charge.



Verify the functionality of the emergency button, pushing the emergency button and verifying the stop of the device.



Verify the functionality of the anti-panic system: push the accelerator lever to start the device, and push further the accelerator lever up to the stop, and verify the stop of the device. Release the accelerator lever to disarm the anti-panic system.



Rotate clockwise the emergency button to rearm the device.



NOTE!

Before every use carry out a function check with the device unloaded to check for any problems with the engine.

PowerSeat PWRS-B

USING THE DEVICE - ADJUSTING THE ACCELERATOR CONTROL POSITION

Before using the device verify the position of the accelerator control so that it is ergonomically comfortable for the operator, depending on the use that is expected.



1. After having unplugged and removed the battery, unscrew the (first) anchor screw that connects the accelerator control with the loom.



2. Unscrew the second screw in the accelerator control with an Allen wrench no. 4. Please watch out not to lose the self-locking nut.



3. Slip off the accelerator control from the bearing, and insert it in the PowerSeat loom.

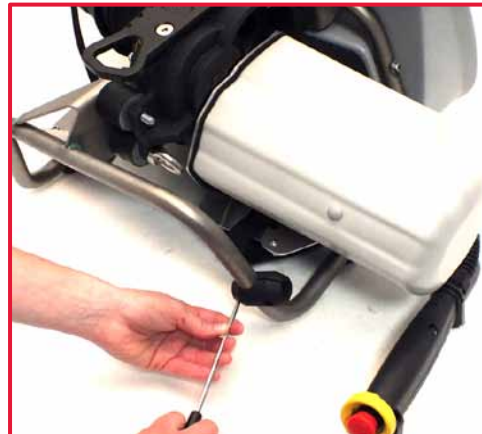

4. Install back the accelerator bearing.



5. Install back the accelerator control in the bearing, and tighten the screws.

USING THE DEVICE - ADJUSTING THE CONTROL LEVER POSITION

Before using the device it is possible set up the position of the control lever so that it is ergonomically comfortable for the operator, depending on the use that is expected.



1. Loose the control lever screw using an hex key n°5.



2. Place the control lever on one of 3 possible position.



2. Place the control lever on one of 3 possible position.



3. Tighten the control lever screw.

PowerSeat PWRS-B

USING THE DEVICE - PRIMARY ROPE INSTALLATION PROCEDURE



1. Place the PowerSeat on the ground.



2. Pull open the clamp and slide the front tube into the housing.



WARNING!

Slide the front tube correctly into its housing until the red reference mark is no longer visible.



3. Pass the rope inside the pin.



4. Fit the rope into the front tube.



5. Pass the rope round the pulley.



6. Make sure the rope has been fitted correctly into its housing.



7. Wind the rope clockwise around the winch drum.



8. Pass the rope over the stripper arm.



WARNING!

Take at least two turns of the rope around the winch drum, and if it slips under load increase the number of turns to a maximum of four, taking care not to overlap the rope.



NOTE!

The number of turns needed round the winch drum depends on the load and the condition of the rope. Check the device's descending capacity in its working configuration. Before use ascend with the device, no more than 1 mtr (3,28 ft) and check, according to the descent procedure 1, that it's descending smoothly. In case of difficulties unwind the rope, and reduce the turns to not less than 2 wraps, until you have the optimal configuration.

PowerSeat PWRS-B



9. Fit the rope into the rope grab. Raise the cover to make this easier.



10. Position the rope inside the stopper.

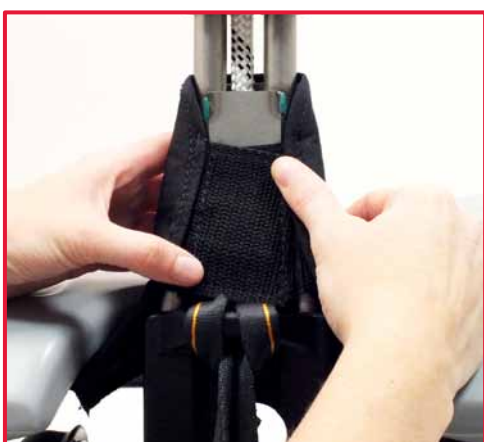

11. Close the protective cover with the strap.

USING THE DEVICE - WIRING THE BATTERY



1. Place the battery in its holder.



2. Connect the protective cover.



3. Make sure that the hooks of the protective cover is positioned on the flat surface of the battery.



4. Connect the battery grip to the power cable of the motor.



5. Turn on the battery with the switch 0/1, and check the state of charge.



WARNING!

Disconnect the battery from the PowerSeat when you finished to use it.

PowerSeat PWRS-B

USING THE DEVICE - PREPARING TO ASCEND

Install two ropes, Primary and Secondary, with separate anchorage points. Each rope must support at least 15 kN.

Install the Primary (or working) rope on the device as directed "Primary Rope Installation Procedure" paragraph.

Attach the Secondary (or backup) rope is attached to the operator using a fall arrest device (EN353/2 approved) and energy absorber (EN355 approved).

Both ropes must be EN1891 Class A certified and have a diameter of between 10 (1/8") and 12.7 mm (1/2").

In the case of fault or breakage of the device or of the primary rope, the load will be immediately transferred to the secondary rope through the fall arrest device, thus constituting the anti-fall system.



WARNING!

Use the PowerSeat only with the primary and secondary ropes installed so as to create the anti-fall system described above.

To use the PowerSeat the operator must also wear:

1. A full EN 361 and EN813 certified harness to which the device is attached at the lower front attachment and the fall arrest device at the upper front attachment
2. An EN 795 B certified waist strop connected to the two side attachments of the harness and passing outside the front tube of the PowerSeat
3. Appropriate Individual Personal Protective Equipment (PPE) (e.g. helmet, gloves and protective glasses)
4. Suitable clothing, form fitting so it cannot catch on moving parts



Pos.	Description
1	Primary Rope
2	Secondary Rope
3	Fall Arrest Device
4	Upper Front Attachment
5	Full Harness
6	Waist Strop
7	Lower Front Attachment
8	Side Attachment Points
9	Helmet
10	Protective Glasses
11	Gloves



WARNING!

Do not use the PowerSeat in the case of illness, tiredness or if under the influence of drugs or alcohol.



Warning!

Keep your hands, feet and clothing etc away from the moving parts of the device.



Warning!

During the ascent the motor cover could become hot. Handle the device with care to avoid injury.



Warning!

During the use of the device any knots on the rope, if they are involved in the device circuit, may damage the device and cause dangerous conditions.



Note!

Before using the PowerSeat make sure that the power cable length is greater than the distance between the Power Supply and the higher ascending point of the device.

USING THE DEVICE - ASCENT PROCEDURE 1

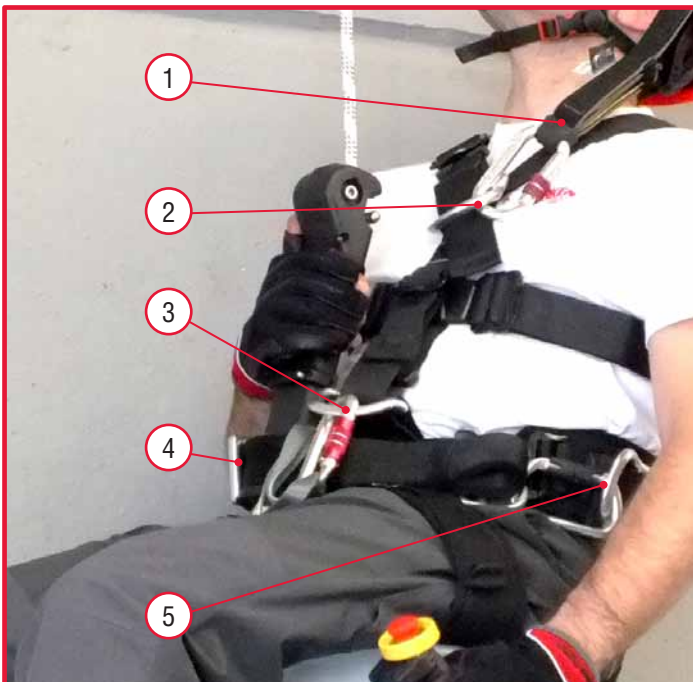

Pos.	Description
1	Fall Arrest Device
2	Upper Front Attachment
3	Lower Front Attachment
4	Waist Strop
5	Side Attachment Points

1. Install the primary rope on the device as indicated in the "Primary Rope Installation Procedure" paragraph.
2. Wire the power system following "Procedure for wiring the battery" paragraph.
3. Supply voltage to the motor by turning on the battery
4. Sit on the device.
5. Connect the fall arrest device to the harness as described in the "Preparing to Ascend" paragraph.
6. Connect the waist strop to the two side attachment points of the harness, passing it outside the front tube of the PowerSeat.

PowerSeat PWRS-B

7. Connect the snap-hook provided with the device to the lower front attachment point of the harness.



8. Adjust the position of the accelerator control so it is ergonomically comfortable for the operator.



9. To ascent, push the accelerator lever to the first detent.



WARNING!

Before using the device check that the rope is correctly installed.



WARNING!

Before using the device test the functionality of the emergency button and the anti-panic system.

USING THE DEVICE - ASCENT PROCEDURE 2

1. Install the primary rope on the device as indicated in the “Primary Rope Installation Procedure” paragraph.
2. Wire the power system following "Wiring the Battery" paragraph.
3. Adjust the position of the accelerator control so it is ergonomically comfortable for the operator as indicated in the "Adjusting the Accelerator Control Position" paragraph.
4. Supply voltage to the motor by turning on the battery
5. Operate the device and position it at the height of the operator’s shoulders.
6. Connect the fall arrest device to the harness as described in the “Preparing to Ascent” paragraph.



7. Connect the snap-hook supplied with the device to the lower front attachment point of the harness.
In ascent procedure 2 the Waist strop is not used
8. To ascent, push the accelerator lever to the first detent.

**WARNING!**

Before using the device check that the rope is correctly installed.

**WARNING!**

Before using the device test the functionality of the emergency button and the anti-panic system.

USING THE DEVICE - USING POWERSEAT WITH A FIXED POINT



NOTE!

To use the PowerSeat with a fixed point at least two operators are necessary. One operates the device and the second is connected by the primary rope to the device and to the secondary rope by the (EN353/2 approved) fall arrest device. Both ropes must be EN1891 certified and have a diameter of between 10 (1/8") and 12.7 mm (1/2"). The secondary rope must have an anchorage point that supports at least 15kN. The device is connected to a fixed anchorage point on the ground which must support at least 15kN.



1. Pull the clamp and slide out the front tube.



2. Unscrew the four screws that fix the seat to the chassis with a n°5 hex key.



3. Remove the seat.

4. Adjust the position of the accelerator control so it is ergonomically comfortable for the operator as indicated in the "Adjusting the Accelerator Control Position" paragraph.
5. Place the control lever position following the "Adjusting the Control Lever Position" paragraph.
6. Install the primary rope on the device as indicated in the "Primary rope installation procedure" paragraph. In this case the primary rope will be used to lift the second operator.
7. Wire the power system as described in "Wiring the Battery"
8. Connect the anchorage point on the front plate of the device with the fixed anchorage point on the ground.
9. Supply voltage to the motor by turning on the battery
10. To ascent, push the accelerator lever to the first detent.



WARNING!
Do not use the PowerSeat with the battery leaning on the ground or on the wall.



WARNING!
To use the PowerSeat in the fixed point configuration the primary rope under load must leave the winch with a lateral and frontal angle of between $\pm 6^\circ$.

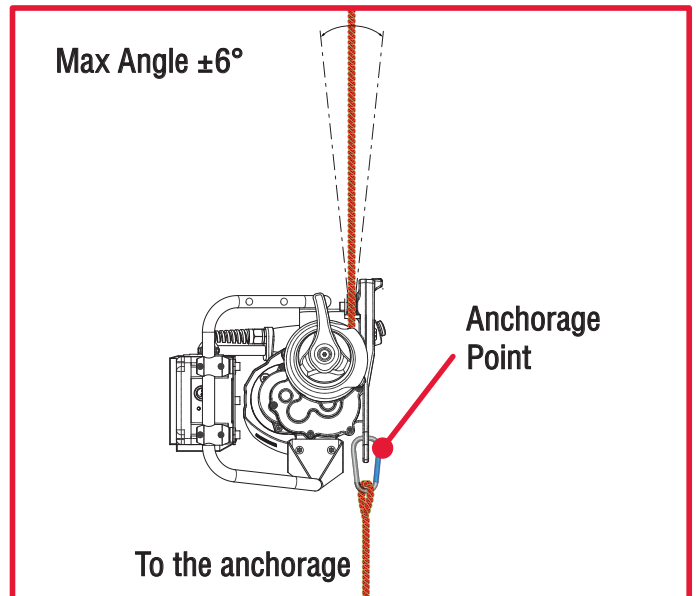
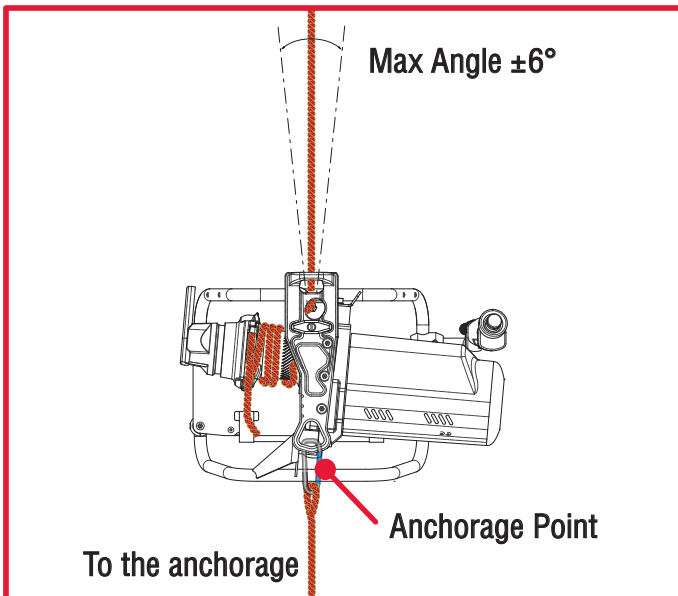

WARNING!
Before using the device check that the rope is correctly installed.



WARNING!
Before using the device test the functionality of the emergency button and the anti-panic system.

PowerSeat PWRS-B

USING THE DEVICE - DESCENT PROCEDURE 1



1. With one hand grasp the rope leaving the winch.



2. With the other hand, turn the control lever clockwise to allow the rope to slip on the winch drum and permit a controlled descent. To adjust descent speed, manually control the speed at which the rope leaves the winch by holding rope with arm out and bringing it in towards the winch drum.

To stop the descent, release the control lever.



To facilitate descent, a carabiner can be fixed to the ring on the front tube and the primary rope passed through it.



NOTE!

Take care not to overbalance when getting off the seat. Lower the PowerSeat until the operator's feet are firmly on the ground, but the unit is still suspended. Stand up and move on the seat. Now the device can be lowered to the ground and released from the rope.

USING THE DEVICE - DESCENT PROCEDURE 2



1. With one hand grasp the rope leaving the winch.



2. With the other hand, turn the control lever clockwise to allow the rope to slip on the winch drum and permit a controlled descent. To adjust descent speed, manually control the speed at which the rope leaves the winch. To stop the descent, release the control lever.

USING THE DEVICE - FIXED ANCHORAGE DESCENT PROCEDURE

1. With one hand grasp the rope leaving the winch.

2. With the other hand, turn the control lever clockwise to allow the rope to slip on the winch drum and permit a controlled descent. To adjust descent speed, manually control the speed at which the rope leaves the winch. To stop the descent, release the control lever.

USING THE DEVICE - TRANSPORT AND STORAGE

Transport the device using the box provided at time of purchase. To transport the device disconnect the Power Supply system. When not in use the device must be stored in its box in order to protect it from knocks and shock. Protect the device from humidity and temperature range. The temperature required for storage must be in the range $-25^{\circ}\text{C}/+55^{\circ}\text{C}$, and for periods not exceeding 24 hours the maximum temperature can reach $+70^{\circ}\text{C}$. The humidity is not expected to exceed 80%. Do not allow the device to come into contact with corrosive substances. Clean the device before storing.

PowerSeat PWRS-B.Compact

DESCRIPTION OF COMPACT VERSION - GENERAL

The PowerSeat Compact version maintains every device key features described in the "Device Description" paragraph.

This device version is designed to optimize the qualified operator's work when he works without seat or using the device with a fixed anchorage.

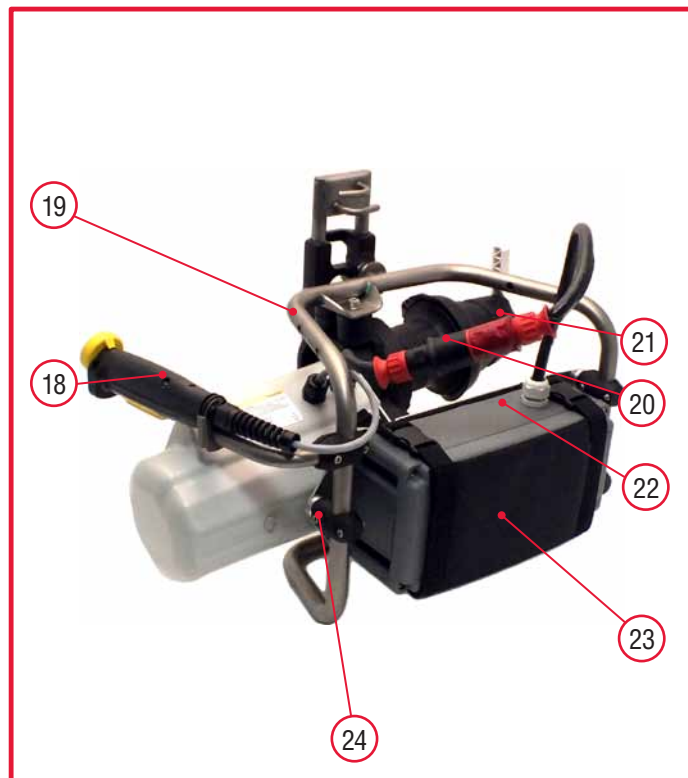
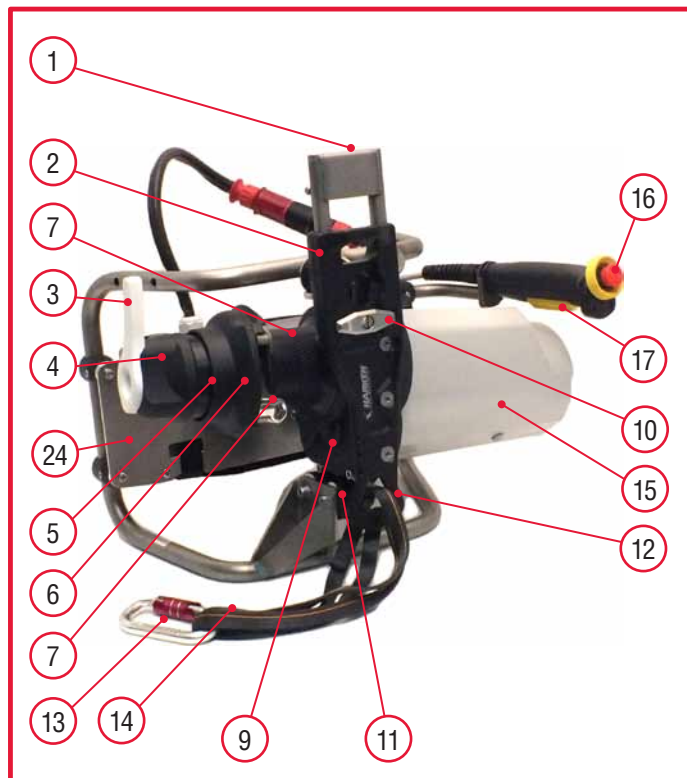

Pos.	Description
1	Short Tube
2	Front Plate
3	Control Lever
4	Knob
5	Cover
6	Rope Grab
7	Stripper arm
8	Winch Drum
9	Reduction Gear Casing
10	Calmp
11	Damper
12	Anchorage Point

Pos.	Description
13	Snap-hook
14	Strop
15	Motor Cover
16	Emergency Button
17	Accelerator Lever
18	Accelerator Control
19	Frame
20	Motor Power Cable
21	Battery Power Cable
22	Battery
23	Protection Pad
24	Battery Support Plate

DESCRIPTION OF COMPACT VERSION - DIMENSIONS

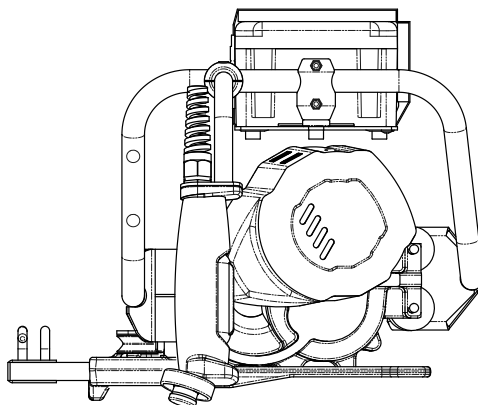
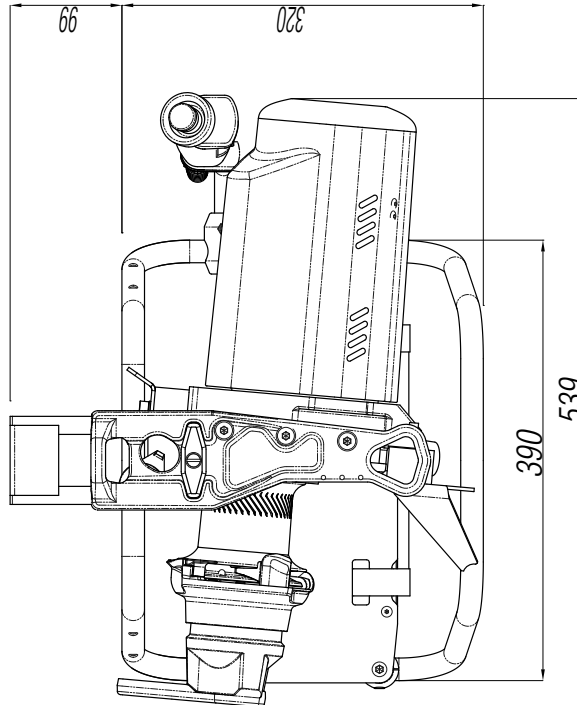
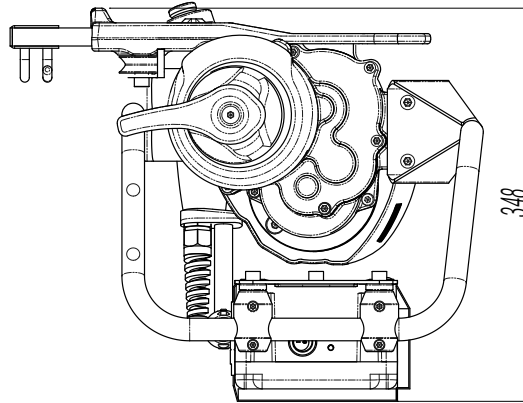

PowerSeat PWRS-B.Compact

USING THE COMPACT VERSION DEVICE - CHECKING THE COMPACT VERSION DEVICE BEFORE USE

Before and after using the PowerSeat Compact version follow the procedure described in the "Checking the Device Before Use" paragraph.

USING THE COMPACT VERSION DEVICE - PRIMARY ROPE INSTALLATION PROCEDURE ON COMPACT VERSION



1. Place the PowerSeat on the ground.

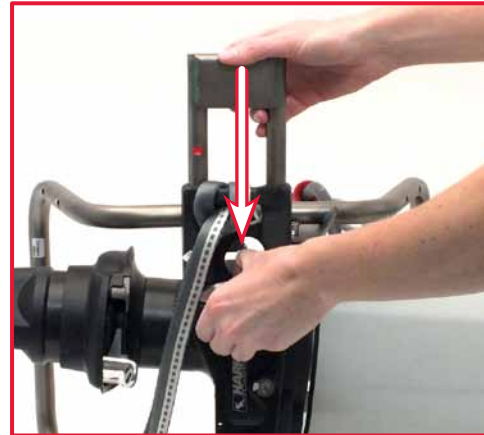

2. Pull open the clamp and slide the short tube into the housing.



WARNING!

Slide the front tube correctly into its housing until the red reference mark is no longer visible.



3. Remove the strop from upper anchorage point.



4. Fasten the strop on the lower anchorage point.



5. Pass the primary rope inside the pins.

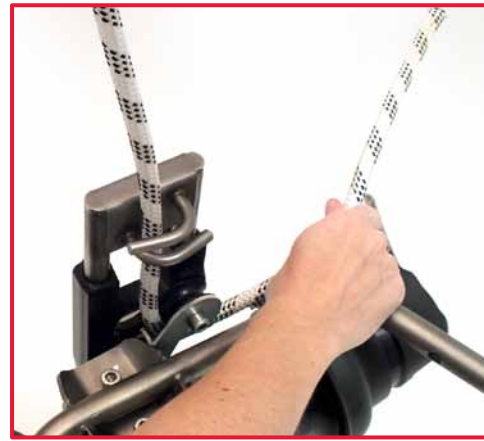

6. Pass the rope round the pulley.

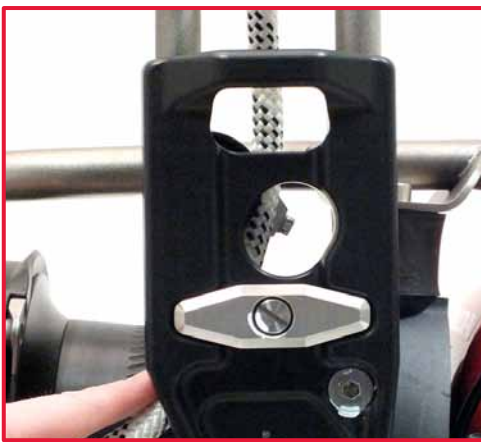

7. Make sure the rope has been fitted correctly into its housing.



8. Wind the rope clockwise around the winch drum.



WARNING!

Take at least two turns of the rope around the winch drum, and if it slips under load increase the number of turns to a maximum of four, taking care not to overlap the rope.



NOTE!

The number of turns needed round the winch drum depends on the load and the condition of the rope.

Check the device's descending capacity in its working configuration.

Before use ascend with the device, no more than 1 mtr (3,28 ft) and check, according to the descent procedure 1, that it's descending smoothly.

In case of difficulties unwind the rope, and reduce the turns to not less than 2 wraps, until you have the optimal configuration.

PowerSeat PWRS-B.Compact



9. Pass the rope over the stripper arm.



10. Fit the rope into the rope grab. Raise the cover to make this easier.

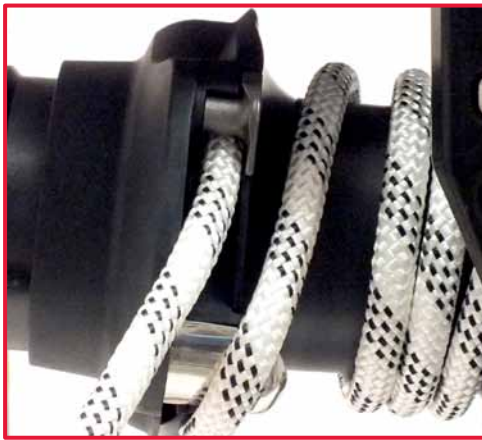

10. Position the rope inside the stopper.

USING THE COMPACT VERSION DEVICE - PREPARING TO ASCENT WITH THE COMPACT VERSION

To use the PowerSeat Compact version follow the procedure described in "Preparing to Ascent" paragraph.



WARNING!

Read carefully the section "Preparing to Ascent" before using the machine.

USING THE COMPACT VERSION DEVICE - ASCENT PROCEDURE WITH THE COMPACT VERSION

1. Install the primary rope following "Primary Rope Installation Procedure on Compact version" paragraph.
2. Wire the power system following "Wiring the Battery" paragraph.
3. Adjust the position of the accelerator control so it is ergonomically comfortable for the operator as indicated in the "Adjusting the Accelerator Control Position" paragraph.
4. Supply voltage to the motor by turning on the battery
5. Operate the device and position it at the height of the operator's shoulders.
6. Connect the fall arrest device to the harness as described in the "Preparing to Ascent" paragraph.



7. Connect the snap-hook supplied with the device to the lower front attachment point of the harness.

In ascent procedure 2 the Waist strop is not used

8. To ascent, push the accelerator lever to the first detent.



WARNING!

Before using the machine, check that the cable is correctly installed.



WARNING!

Before using the machine, check that the emergency button and the panic function working properly.

USING THE COMPACT VERSION DEVICE - USING COMPACT VERSION POWERSEAT WITH A FIXED ANCHORAGE



NOTE!

Using the fixed point PowerSeat needs at least two devices. One of them will start the machines, whilst the other one must be connected to the machine through the principal as well as secondary rope via the anti-fall device (approved as of regulation number EN353/2).

Both ropes must be certified as of regulation number EN1891, and their diameter must be between 10 and 12.7mm. The secondary rope's anchorage capacity must be at least 15 kN. The machine is connected to a soil anchorage point which must be able to bear at least 15 kN.

1. Adjust the position of the accelerator control so it is ergonomically comfortable for the operator as indicated in the "Adjusting the Accelerator Control Position" paragraph.

2. Set the control lever position following the "Adjusting the Control Lever Position" paragraph.

3. Install the primary rope on the device as indicated in the "Primary rope installation procedure on Compact version" paragraph. In this case the primary rope will be used to lift the second operator.

4. Wire the power supply system as described in the "Wiring the Battery" paragraph.

5. Connect the anchorage point on the front plate of the device with the fixed anchorage point on the ground.

PowerSeat PWRS-B.Compact

- Supply voltage to the motor by turning on the 48V Power Supply.
- To ascent, push the accelerator lever to the first detent.



WARNING!
Do not use the PowerSeat with the battery leaning on the ground or on the wall.



WARNING!
To use the PowerSeat in the fixed point configuration the primary rope under load must leave the winch with a lateral and frontal angle of between $\pm 6^\circ$.

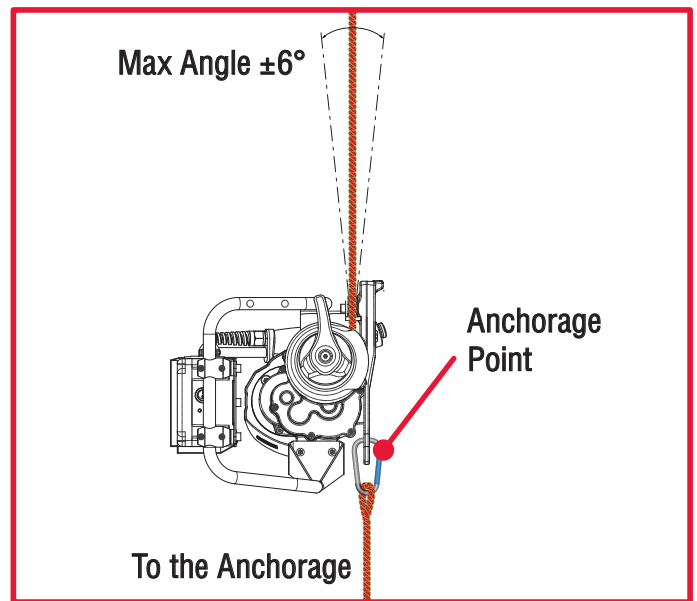
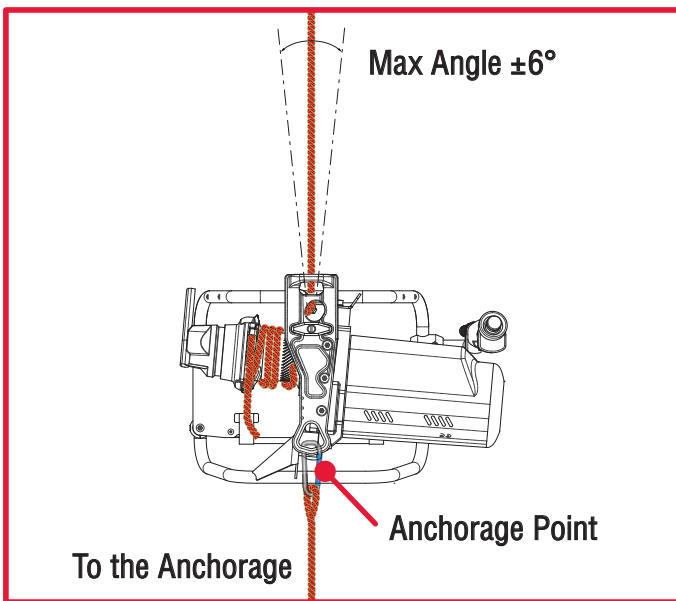

WARNING!
Before using the device check that the rope is correctly installed.



WARNING!
Before using the device test the functionality of the emergency button and the anti-panic system.

USING THE COMPACT VERSION DEVICE - DESCENT PROCEDURE WITH THE COMPACT VERSION



1. With one hand grasp the rope leaving the winch.



2. With the other hand, turn the control lever clockwise to allow the rope to slip on the winch drum and permit a controlled descent. To adjust descent speed, manually control the speed at which the rope leaves the winch. To stop the descent, release the control lever.

USING THE COMPACT VERSION DEVICE - FIXED ANCHORAGE DESCENT PROCEDURE WITH THE COMPACT VERSION

1. With one hand grasp the rope leaving the winch.

2. With the other hand, turn the control lever clockwise to allow the rope to slip on the winch drum and permit a controlled descent. To adjust descent speed, manually control the speed at which the rope leaves the winch. To stop the descent, release the control lever.

USING THE COMPACT VERSION DEVICE - CONVERTING THE POWERSEAT PWRS-G IN THE COMPACT VERSION

To obtain the Compact version from PowerSeat PWRS-G it is required to buy the short tube and follow the procedure described below:



1. Pull open the clamp and slide out the front tube.



2. Unscrew the four screws that fix the seat to the chassis with a n°5 hex key.

PowerSeat PWRS-B.Compact



3. Remove the seat.

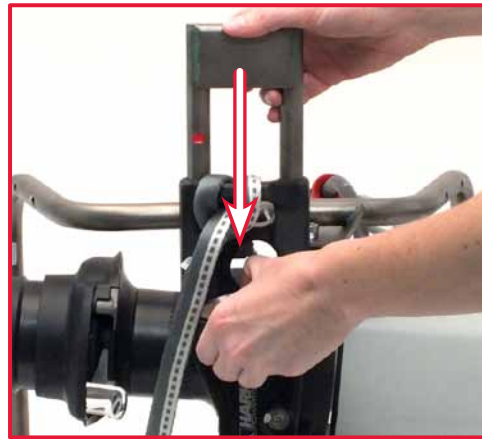

4. Pull open the clamp and slide the short tube into the housing.



WARNING!

Slide the front tube correctly into its housing until the red reference mark is no longer visible.

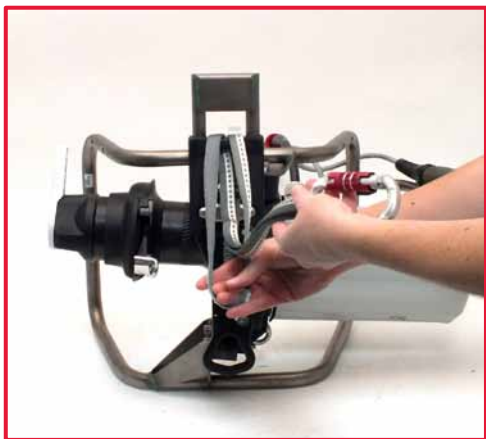

5. Remove the stop from upper anchorage point.



6. Fasten the stop on the lower anchorage point.

CLEANING

Regularly clean and dry the device with a damp cloth to remove accumulated dirt. Do not use a direct jet of water or a high pressure water jet cleaner. Do not use degreasing products, solvents or abrasive pastes.

MAINTENANCE

Before and after every use visually inspect the PowerSeat for traces of wear, damage or breakage. Refer to the "Checking the device before use" paragraph for more detail on this inspection.

Every year, once a year send the device to the manufacturer or to an authorized Harken Service Center for a complete inspection. For a list of authorized service centers please visit the website www.power-seat.com.

The first year, the device must be sent to the manufacturer within 12 months from the date of purchase. The non-observance of such condition invalidates the warranty of the machine.

The maintenance must be recorded in the Maintenance Schedule.

Dismantling and Disposal

When the device is dismantled, it is necessary to separate the parts in plastic, those in metal and electrical components, which must be sent to differentiated disposal centres in accordance with the regulations of the country where the device is dismantled.

Flat batteries must be sent to trash separation and collection points, respecting the current regulations of the country where the batteries will be disposed.



Diagnosis and Fault Finding

POWERSEAT AND ENGINE

Problem	Possible Causes	Possible Solutions
The rope slips on the winch drum	- too few turns around the winch drum	- take another turn of the rope round the winch drum
	- diameter of rope not in prescribed range	- replace the rope
The engine does not start	- incorrect engine starting procedure	- refer to "Wiring the Power Supply System" paragraph in this User Manual - verify that the emergency button is disarmed - verify the integrity of the cable and its connectors - verify that the input voltage it is in the correct range
	- the ignition process is not correct and/or the battery wiring	- refer to the "Diagnosis and Fault Finding" relative to the battery
	- engine fault	- contact Harken for more informations
	- it is activated the motor thermal protection	- wait until the motor temperature is below the block temperature. This operation may take several tens of minutes.
Limited lifting capacity	- engine malfunctioning	- contact Harken Tech Service for more informations
	- overload condition	- reduce the load

Diagnosis and Fault Finding

Difficult descent	<ul style="list-style-type: none">- too many wraps on winch drum- rope grab system possible malfunctioning	<ul style="list-style-type: none">- unwind the rope, reducing wraps. Leave at least 2 wraps on winch drum- contact Harken Tech Service for more information
-------------------	-----------------------------------------------------------------------------------------------------------------------------------	------------------------------------------------------------------------------------------------------------------------------------------------------------------------------------

BATTERY

Problem	Possible Causes	Possible Solutions
The battery does not charge	- the battery charger is not connected (the light on the battery charger is switched off)	- connect the battery charger
	- the battery is disconnected	- verify the wiring
	- the battery is switched off	- verify that the 0/1 button is on the "1" position
	- battery temperature is outside the 0/+40 °C range	- wait for the temperature to come back to the 0/+40 range
	- the battery fuse is burned	- the battery has to be sent to Harken in order to be repaired
	- the battery charger fuse is burned	- change the fuse (ATM - automotive mini - 7.5 A)
	- the battery charger is damaged	- change the battery charger
PWRS does not work	- the battery is switched off	- verify that the 0/1 button is on the "1" position
	- the battery is disconnected	- verify the wiring
	- the battery is in stand-by	- switch off and then switch on the battery
	- the battery is not charged (fixed red LED light)	- verify that the battery is charged, and possibly charge it
	- the temperature of the battery is outside the range -10/+50°C	- wait for the temperature to come back to the -10/+50 range
	- the battery is damaged	- the battery has to be sent to Harken in order to be repaired
	- the battery is in short circuit (all LEDs are switched off)	- the battery has to be sent to Harken in order to be repaired

Maintenance Schedule

Owner name

Product name and Model

Serial Number

Engine Serial Number

Year of manufacture

Date of purchase

Date of first use

Maintenance interval Annual

Maintenance Schedule

Date of Service	Description of Service	Name and Signature of Maintenance Operator	Date of Next Intervention

HARKEN®

Manufacturer/EU Representative

Harken Italy S.p.A.

Via Marco Biagi 14, 22070 Limido Comasco (CO), Italy

Tel 031.3523511; Fax 031.3520031

Web: www.harken.it

Email: info@harken.it

Worldwide Limited Warranty

Refer to the Harken World Limited Warranty on the website at:

<http://www.power-seat.com/>

The product warranty is accepted only if it has been maintained as specified in this Manual by Harken authorized personnel and is accompanied by Maintenance Schedule properly compiled